



# XenaAppliance

## L2-7 Gigabit Stateful TCP Test Chassis

Product Order Numbers

	XenaAppliance	XA40-I2SFP+
2U	+ M6SFP (L2-3)	XA40-I2SFP+M6SFP
	+ M2SFP+ (L2-3)	XA40-I2SFP+M2SFP+



*XenaAppliance is used for simulating millions of real-world end-user environments to test and validate infrastructure, a single device, or an entire system.*

XenaAppliance is an extreme performance Gigabit TCP test chassis for stateful traffic load testing, analysis and characterization of Ethernet equipment and network infrastructure.

This ultra-compact “all-in-one” chassis supports 1/10G L4-7 interfaces and can also be equipped with 1G or 10G L2-3 test modules, making it a complete L2-7 test platform.

XenaAppliance offers stateful end-to-end testing of network appliances such as switches, firewalls, routers, NAT routers, proxies, load-balancers, bandwidth shapers, and more. The platform is also suitable to characterize entire network infrastructure performance for TCP.

Developers of Ethernet-based network appliances can characterize their performance by measuring connection establishment and teardown rates, packet forwarding rate at large numbers of connections and identify performance bottlenecks. The platform is also ideal for rapid validation of performance or regression testing.

Developers of TCP-based application servers such as web- and FTP servers can measure TCP connection rates and verify robustness against TCP SYN attacks. HTTP get blasting can be used to verify web server performance and robustness.

XenaConnect is included for ad-hoc test execution and remote management of test equipment located in multiple locations. Xena also offers an open scripting API (XenaScripting) for automating testing from any scripting environment and browser-based operation via XenaWeb.

### Extreme Performance:

- 4 million Concurrent Connections (CC)\*
- 2 million Connections Per Second (CPS)\*\*
- 1 million packets capture buffer

\* Using a single XenaAppliance with one port configured as a client, and the other as a server.

\*\* measured at 2 million CC

### Features and Benefits

- Stateful TCP traffic load generation with extreme performance – 4 million TCP connections
- High port density in small (2U) form factor
- Supports dual-speed 1G & 10G SFP optical and copper Ethernet interfaces for L4-7 and L2-3 testing
- Configuration and tuning of Ethernet, IP and TCP header fields for advanced traffic scenarios
- Stateful TCP connection blasting
- HTTP get/put/head/post blasting
- Extensive live stats and test reports
- Wire-speed traffic capture with programmable filter and trigger criteria
- Switched and routed network topologies, TCP proxy and NAT support
- Includes free traffic generation and analysis software included (XenaConnect for L4-7 and XenaManager-2G for L2-3)
- Xena L2-3 test applications (Xena2544, Xena2889, Xena1564 and Xena3918) also included free of charge.
- XenaScripting – automated Command Line Interface (CLI) scripting from any scripting tool environment such as Tcl, Python, Perl, VBA, Ruby, Bash and Java



XenaAppliance supports optical and copper interfaces for 1G & 10G Layer 4-7 and Layer 2-3 testing, in various port densities:

PRODUCT NUMBER	DESCRIPTION
XA40-I2SFP+	XenaAppliance 2-slot chassis (non-modular, fixed), AC power, excl. tvcrs <ul style="list-style-type: none"> <li>• <b>Slot 0:</b> L4-7 Interfaces 2 x SFP+, 2 x 10GBASE-SR/LR/DAC or 1000M optical/copper, 4 Packet Engines, Performance level 40 with 4M cc, and 2M cps@1M cc (*)</li> <li>• <b>Slot 1:</b> N/A</li> </ul>
XA40-I2SFP+M6SFP	XenaAppliance 2-slot chassis (non-modular, fixed), AC power, excl. tvcrs <ul style="list-style-type: none"> <li>• <b>Slot 0:</b> L4-7 Interfaces 2 x SFP+, 2 x 10GBASE-SR/LR/DAC or 1000M optical/copper, 4 Packet Engines, Performance level 40 with 4M cc, and 2M cps@1M cc (*)</li> <li>• <b>Slot 1:</b> L2-3 Test Module 6 x SFP, 6 x 100/1000M optical or 10/100/1000M BASE-T, excl tvcrs</li> </ul>
XA40-I2SFP+M2SFP+	XenaAppliance 2-slot chassis (non-modular, fixed), AC power, excl. tvcrs <ul style="list-style-type: none"> <li>• <b>Slot 0:</b> L4-7 Interfaces 2 x SFP+, 2 x 10GBASE-SR/LR/DAC or 1000M optical/copper, 4 Packet Engines, Performance level 40 with 4M cc, and 2M cps@1M cc (*)</li> <li>• <b>Slot 1:</b> L2-3 Test Module, 2 x SFP+, 2 x 10GBASE-SR/LR optical, excl. tvcrs</li> </ul>

### Slot 0 - Layer 4-7

- 2 x 1/10 GigE SR/LR optical\*
- 2 x 1/10 GigE copper

\* 1 GigE copper w. SFP transceiver

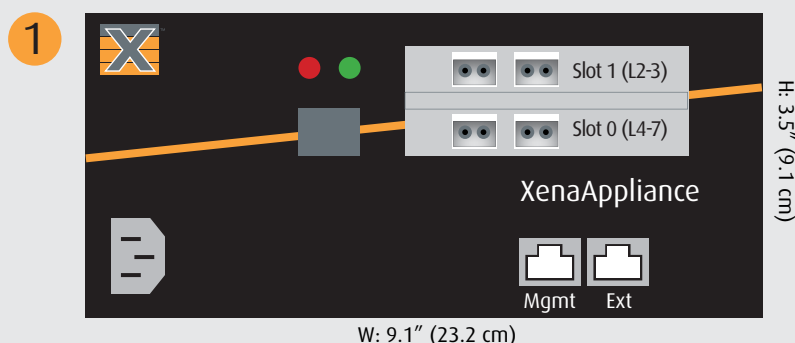

### Slot 1 - Layer 2-3 (optional)

- 6 x 1 GigE (M6SFP) or
- 2 x 10 GigE (M2SFP+)

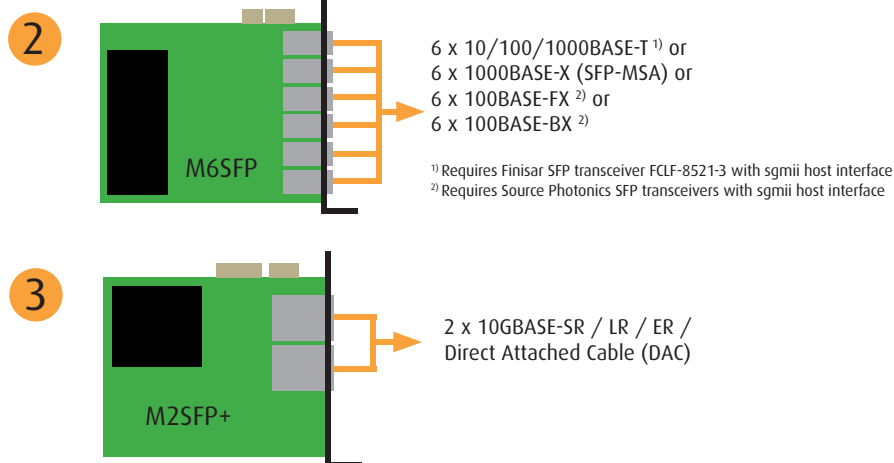

## SPECIFICATIONS

### Dimensions

- Test port slots: 2
- W: 9.1" (23.2 cm)
- H: 3.5" (9.1 cm)
- D: 9.1" (23.2 cm)
- Weight 10lbs (4.5 kg)

### Power

- AC Voltage: 100-240V
- Frequency: 50-60Hz
- Max. Power: 76W
- Max. Current: 0.8A with 120V supply, and 0.4A with 240V supply

### Environmental

- Operating Temperature: 10 to 35° C
- Storage Temperature: -40 to 70° C
- Humidity: 8% to 90% non-condensing

### Regulatory

- FCC (US), CE (Europe)

Distributed by



+49 6103 37 215 910 --- www.neox-networks.com --- sales@neox-networks.com

